

ELECTRICAL SERVICE INSTALLATION GUIDE
FOR FRAME-BUILT STRUCTURES
(OVERHEAD SERVICE DROP)
REVISED 2023

PURPOSE

The purpose of these wiring diagrams is to provide standards for both the layman and experienced electrician so that the design, materials, workmanship and applications of a member's electrical system will be safe, reliable and of adequate capacity. These standards are also important elements in our ability to make connection promptly and efficiently to members' wiring and to accommodate changes and repairs whenever necessary.

NEC AND LOCAL JURISDICTIONS

The standards set forth in this guide are intended to be at or exceed the NEC 2023 standards. Please coordinate with the local governing body for planning commission, building inspection, etc., as their standards may exceed the standards within this guide.

INTRODUCTION

In an effort to minimize confusion and misunderstanding, the Rural Electric Board of Directors have established the following standards:

The Rural Electric will be responsible for all wiring and electric facilities up to and including the point of connection to the member's wiring. The member shall be responsible for

everything from that point on, except that the Rural Electric will always supply and control the meter.

The point of connection and change of responsibility between the member's wiring and that of the Rural Electric shall be:

Rural Electric overhead construction:

- at the weatherhead when the meter is on a building.

- at the top of the meter pole with the meter on a pole (the Rural Electric will own and control the pole).

- at the member's side of the meter/disconnect panel for a manufactured home or other underground service connection provided by the Rural Electric.

Prior to making a connection to serve any location or structure, or to making a reconnection of a member's wiring, the Rural Electric must observe all wiring and equipment from the point of service connection up to and including the main breaker in the service entrance panel for: grounding, completeness, unsafe conditions, and violations of the National Electric Code. Any unsafe condition or violation observed may be cause for refusal to connect the wiring until satisfactory corrections have been made.

All poles, pedestals and combination meter-breaker panels used by the Rural Electric must be wholly owned and controlled by the Rural Electric. No work will be permitted on any of them by anyone other than a qualified, on-duty, Rural Electric employee.

Employees of the Rural Electric are not permitted to work on a member's wiring or equipment other than to connect wiring at the connection point to the Rural Electric's facilities, or to take emergency action to eliminate an immediate threat to life or property.

SAFETY NOTICE

No one other than a qualified Rural Electric employee may make any connection on a Rural Electric pole, except at ground level after service has been disconnected. **Meter seals and meters must not be removed for any reason.**

NOTICE

This publication was prepared by Jackson County Rural Electric Membership Corporation. Neither this organization nor any person acting on behalf of it: (a) makes any warranty, expressed or implied, with respect to the use of any information, apparatus, method or process disclosed in this publication or that such use may not infringe privately owned right; or (b) assumes any liabilities with respect to the use of, or for damages resulting from the use of, any information, apparatus, method or process disclosed in the publication.

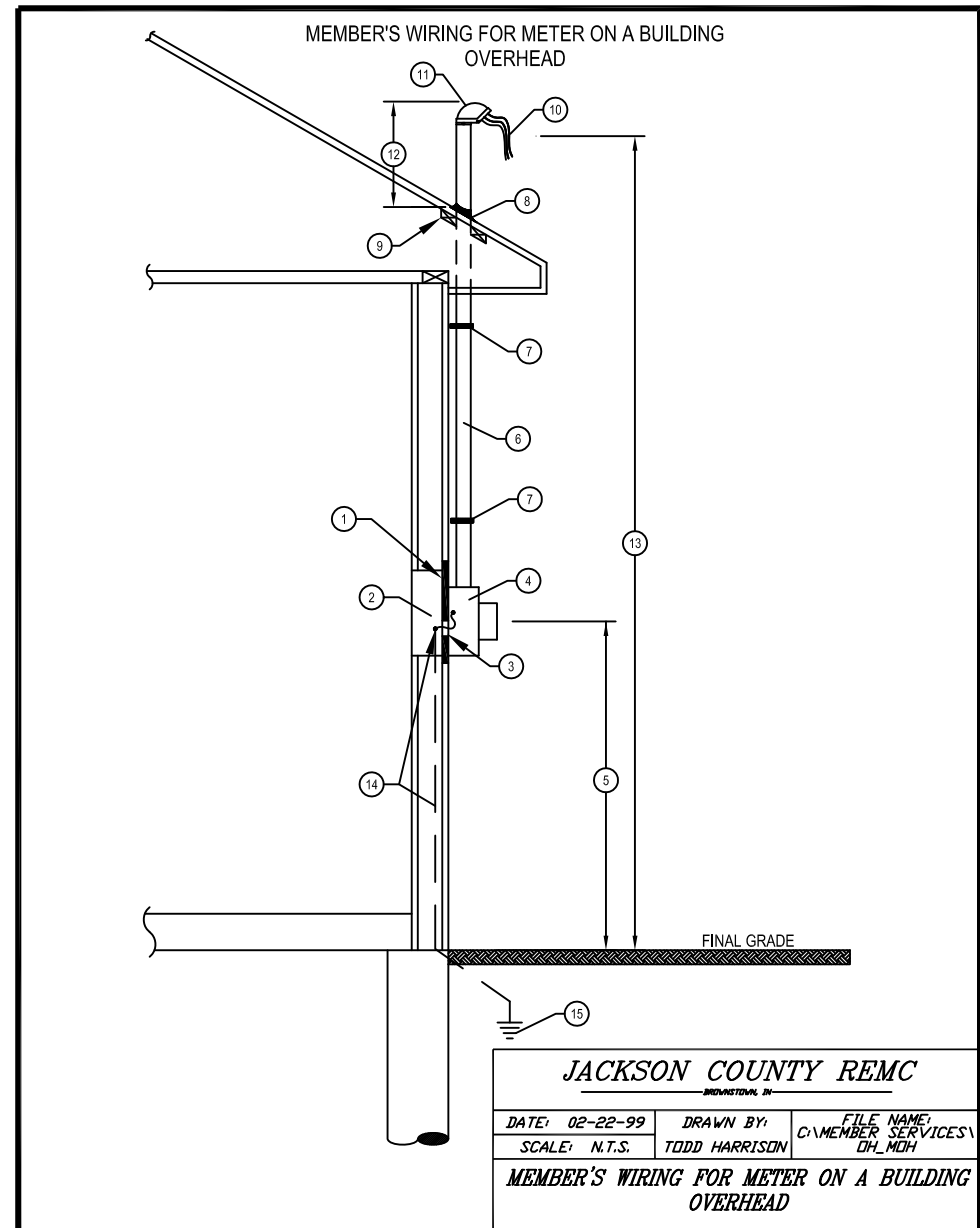

**MEMBER'S WIRING FOR METER ON A
BUILDING-OVERHEAD**

A Rural Electric staking engineer must approve meter locations.

- 1.) Install ½" plywood (in place of the weatherboard) on the exterior framing of the building on which to mount the meter base.
- 2.) Securely fasten the electrical service entrance panel to the interior structure of the building. Normally the panel is recessed in the wall between two 2 X 4's.
- 3.) The wiring that runs between the panel and the meter base shall be in conduit.

A.) The installation of SE type cable may preclude the use of conduit between meter base and panel.

A threaded nipple of gray electrical PVC or rigid steel can be used. Conduit should be properly adapted to both the panel and the meter base by using male adapters, steel locknuts, and plastic bushings. If steel or metallic conduit is used, then grounding bushing should be installed on the threaded portions of the conduit located in the panel and meter base. See chart 1C for service entrance conduit and chart 1D for service entrance conductor sizing.

- 4.) Securely fasten the meter base to the structure of the building. The meter base will need to be fastened to the structure of the building with at least four wood screws.
- 5.) The meter base should be installed approximately 60-66 inches above final grade to the center of the meter base.
- 6.) Install a two inch rigid steel conduit riser from the meter base up through the roof.
- 7.) Securely fasten the riser to the building with conduit standoff brackets or two hole straps.
- 8.) Install a two inch neoprene roof flashing boot over the newly installed riser to prevent water from leaking around it.
- 9.) Two by four inch wood blocking between the rafters should be installed in order to give stability to the riser.
- 10.) Install the service entrance conductors in the riser leaving approximately twenty-four inches hanging out of the top of the riser. The neutral conductor should be properly identified with a six inch wide marking of white electric tape. See chart 1D for the service entrance conductor sizing.
- 11.) Install a two inch weatherhead on top of the riser. The service entrance conductors should hang out of the weatherhead approximately eighteen to twenty inches.
- 12.) The weatherhead should not be higher than three feet above the roof. This is from the lowest point where the riser exits the roof to the top of the weatherhead.

- 13.) The service conductors must meet the following clearances from final grade:
- A.) 10 feet clearance at the service entrance; at the lowest point of the drip loop; at areas accessible to pedestrians; above sidewalks.
 - B.) 12 feet clearance over residential property and driveways.
 - C.) 18 feet clearance over public roads.
- 14.) Install a grounding conductor from the panel out to a grounding electrode. See chart 1A for grounding conductor sizing.
- 15.) Install a grounding electrode (ground rod) approximately eighteen inches away from the foundation of the building. The grounding electrode needs to be approximately six inches below final grade. Leave the grounding electrode and grounding clamp exposed until a Rural Electric employee has performed a safety check. Grounding electrode and clamp sizing can be found on chart 1B.

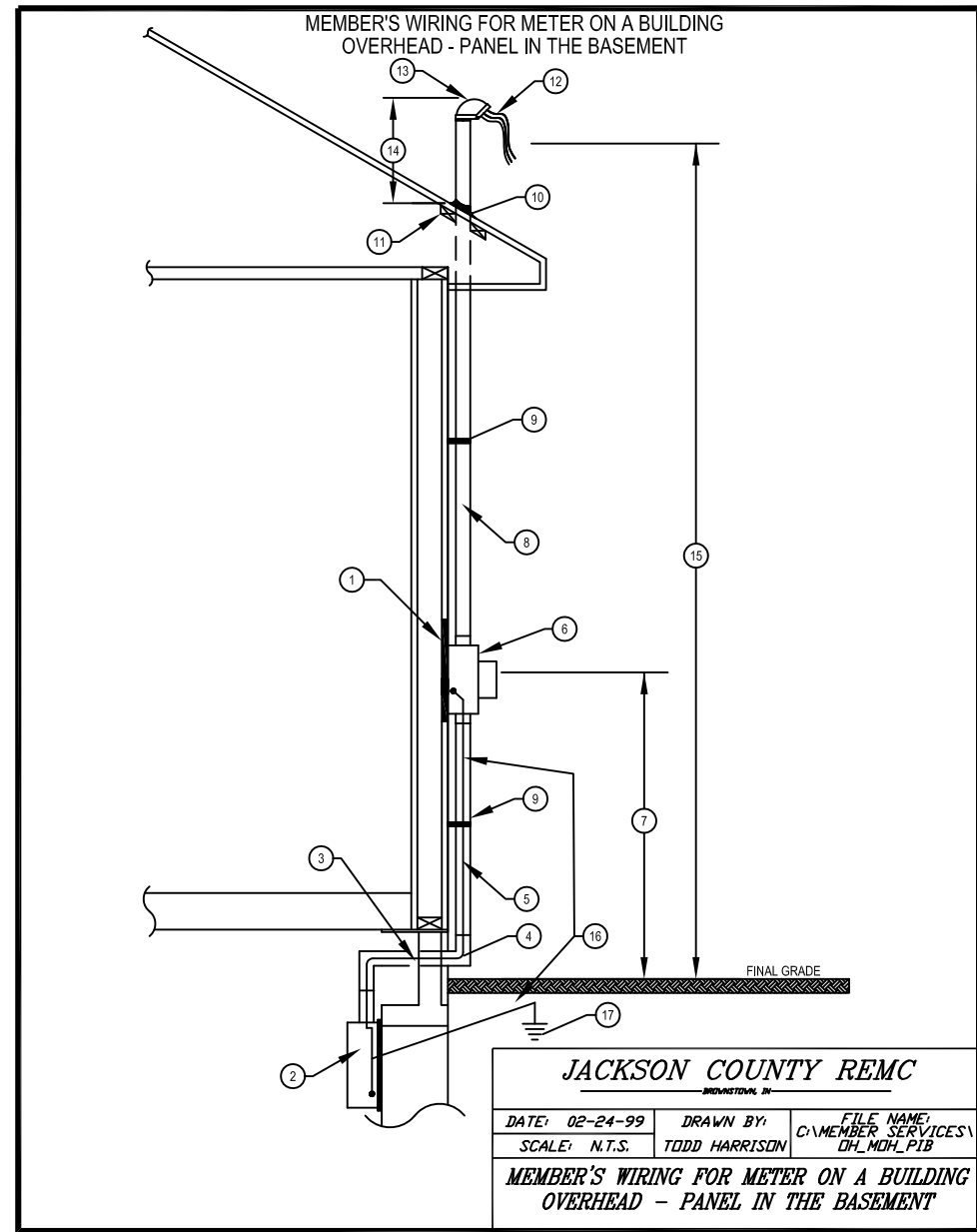

**MEMBER'S WIRING FOR METER ON A BUILDING
OVERHEAD WIRING-PANEL IS IN THE BASEMENT**

**A Rural Electric staking engineer must approve meter
locations.**

- 1.) Install ½ " plywood (in place of the weatherboard) on the exterior of the building in order to mount the meter base.
- 2.) Securely fasten the electrical service entrance panel to the interior basement wall of the building. It is a good idea to install a sheet of plywood between the panel and the basement wall.
- 3.) The wiring that runs between the panel and the meter base shall be in conduit.
 - A.) The installation of SE type cable may preclude the use of conduit between meter base and panel.

A threaded nipple of gray electric PVC or rigid steel can be used. Conduit should be properly adapted to the electrical service entrance panel by using male adapters, steel locknuts, and plastic bushings. If steel or metallic conduit is used, then grounding bushings should be installed on the threaded portions of the conduit located in the panel and the meter base. See charts 1C, 1D, and 1E for conduit sizes, service entrance sizes, and "LB" sizing.
- 4.) Install an electrical 90 degree steel or PVC "LB". See chart 1E for "LB" sizing.

- 5.) Install schedule 80 gray electrical PVC or rigid steel conduit from the "LB" up into the meter base. Properly adapt the conduit to the meter base using a male adapter, locknuts, plastic bushing, or grounding bushing depending upon the type of conduit that is installed. See chart 1C for service entrance conduit sizing.
- 6.) Securely fasten the meter base to the structure of the building. The meter base will need to be fastened to the structure of the building with at least four wood screws.
- 7.) The meter base should be installed approximately 60-66 inches above final grade to the center of the meter base.
- 8.) Install a two-inch rigid steel conduit riser from the meter base up through the roof.
- 9.) Securely fasten the riser and service entrance conduit to the building with conduit standoff brackets or two hole straps.
- 10.) Install a two inch neoprene roof flashing boot over the newly installed riser to prevent water from leaking around the riser.
- 11.) Two inch by four inch wood blocking between the rafters should be installed in order to give stability to the riser.
- 12.) Install the service entrance conductors in the riser leaving approximately twenty four inches hanging out of the top of the riser. The neutral conductor should be properly identified with a six inch wide marking of white electric tape. See chart 1D for service entrance conductor sizing.

- 13.) Install a two inch weatherhead on top of the riser. The service entrance conductors should hang out of the weatherhead approximately eighteen to twenty inches.
- 14.) The weatherhead should not be higher than three feet above the roof. This is from the lowest point where the riser exits the roof to the top of the weatherhead.
- 15.) The service conductors must meet the following clearances from final grade:
 - A.) 10 feet clearance at the service entrance, at the lowest point of the drip loop; at areas accessible to pedestrians; above sidewalks.
 - B.) 12 feet clearance over residential property and driveways.
 - C.) 18 feet clearance over public roads.
- 16.) Install a grounding conductor from the panel out to a grounding electrode. See chart 1A for grounding conductor sizing.
- 17.) Install a grounding electrode (ground rod) approximately eighteen inches away from the foundation of the building. The grounding electrode needs to be approximately six inches below final grade. Leave the top of the grounding electrode and the grounding clamp exposed until a Rural Electric employee has performed a safety check. Grounding electrode and clamp sizing can be found on chart 1B.

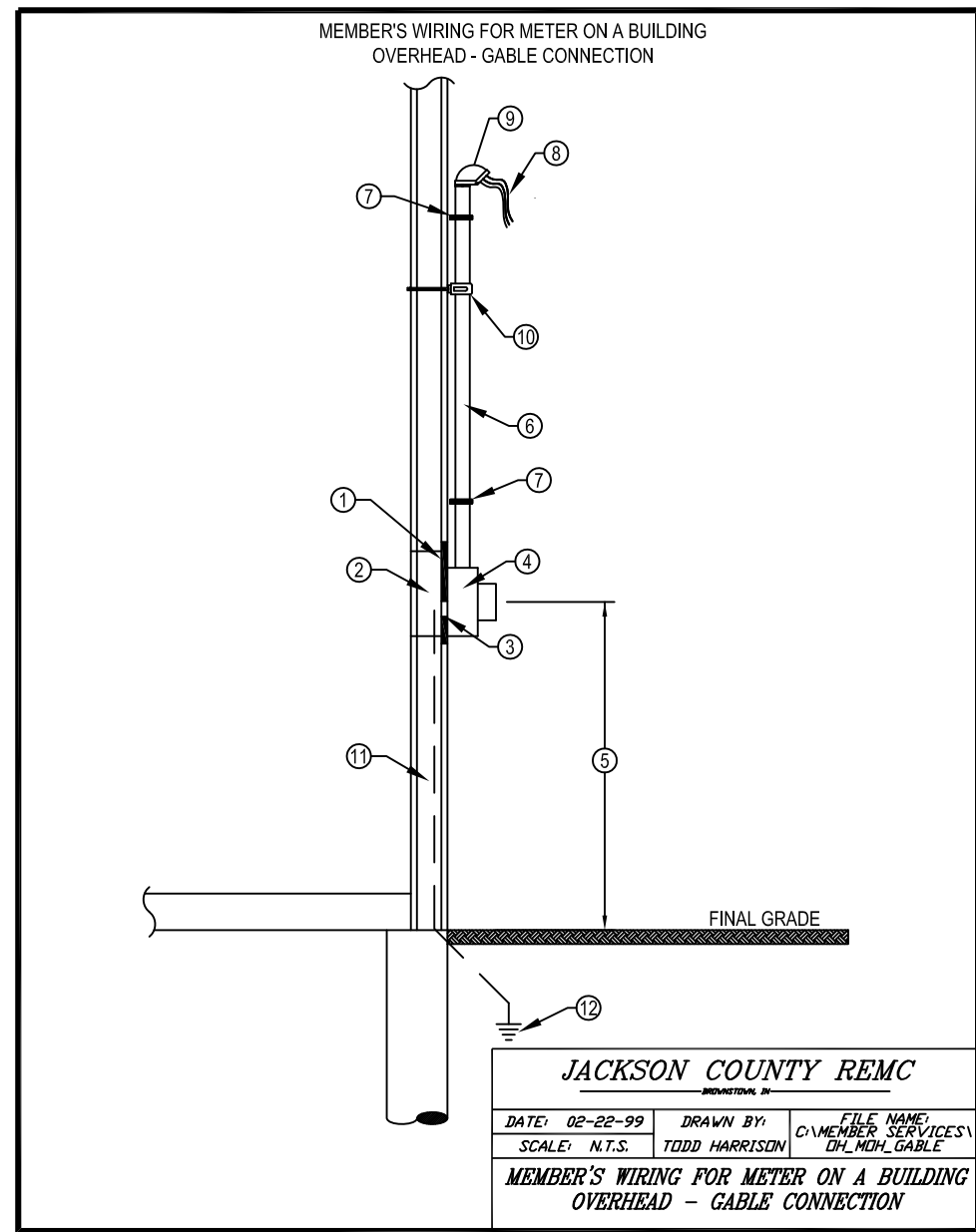

**MEMBER'S WIRING FOR METER ON A BUILDING
OVERHEAD-GABLE CONNECTION**

A Rural Electric staking engineer must approve meter locations.

- 1.) Install ½" plywood (in place of the weatherboard) on the exterior framing of the building on which to mount the meter base.
- 2.) Securely fasten the electrical service entrance panel to the interior structure of the building. Normally the panel is recessed in the wall between two 2 X 4's.
- 3.) The wiring that runs between the panel and the meter base shall be in conduit.
 - A.) The installation of SE type cable may preclude the use of conduit between meter base and panel.

A threaded nipple of gray electrical PVC or of rigid steel can be used. Conduit should be properly adapted to both the panel and the meter base by using male adapters, steel locknuts, and plastic bushings. If steel or metallic conduit is used, then ground bushings should be installed on the threaded portions of the conduit located in the panel and the meter base. See charts 1C for service entrance sizes and 1D for service entrance conductor sizing.
- 4.) Securely fasten the meter base to the structure of the building. The meter base will need to be fastened to the structure with at least four wood screws.

- 5.) The meter base should be installed approximately 60-66 inches above final grade to the center of the meter base.
- 6.) Install schedule 80 gray electrical PVC or rigid steel from the meter base up to a minimum of thirteen feet above final grade. See chart 1C for service entrance conductor sizing.
- 7.) Securely fasten the riser to the building with conduit standoff brackets or two hole straps.
- 8.) Install the service entrance conductors in the riser leaving approximately twenty-four inches hanging out of the top of the riser. The neutral conductor should be properly identified with a six inch wide marking of white electrical tape. See chart 1D for service entrance conductor sizing.
- 9.) Install a weatherhead on top of the riser. The service entrance conductors should hang out of the weatherhead approximately eighteen to twenty inches
- 10.) Install a 5/8" electrical eyebolt through the framing of the building. The eyebolt needs to be installed a minimum of twelve feet above final grade.
- 11.) Install a grounding conductor from the panel out to a grounding electrode. See chart 1A for grounding conductor sizing.
- 12.) Install a grounding electrode (ground rod) approximately eighteen inches away from the foundation of the building. The grounding electrode needs to be approximately six inches below final grade. Leave the grounding electrode and grounding clamp exposed until a Rural Electric employee has performed a safety check. Grounding electrode and clamp sizing can be found on chart 1B.

**MEMBER'S WIRING FOR METER ON THE POLE
OVERHEAD-PANEL IN THE BASEMENT**

A Rural Electric staking engineer must approve meter locations.

- 1.) Securely fasten the electrical service entrance panel to the basement wall of the building. It is a good idea to install a sheet of plywood between the panel and the basement wall.
- 2.) Install a steel nipple or PVC adapter between the "LB" and the service entrance panel. A steel locknut and a grounding bushing should be installed on the threaded portion of the steel nipple that is located in the panel. See chart 1C for service entrance conduit sizing and chart 1E for "LB" sizing.
- 3.) Install an electrical 90 degree steel or PVC "LB". See chart 1E for "LB" sizing.
- 4.) Install a two inch rigid steel conduit riser from the "LB" up through the roof and extending above the roof no more than 36".
- 5.) Securely fasten the two inch riser to the structure of the building with conduit standoff brackets or two hole straps.
- 6.) Install a two inch neoprene roof flashing boot over the newly installed riser to prevent water from leaking around the riser.

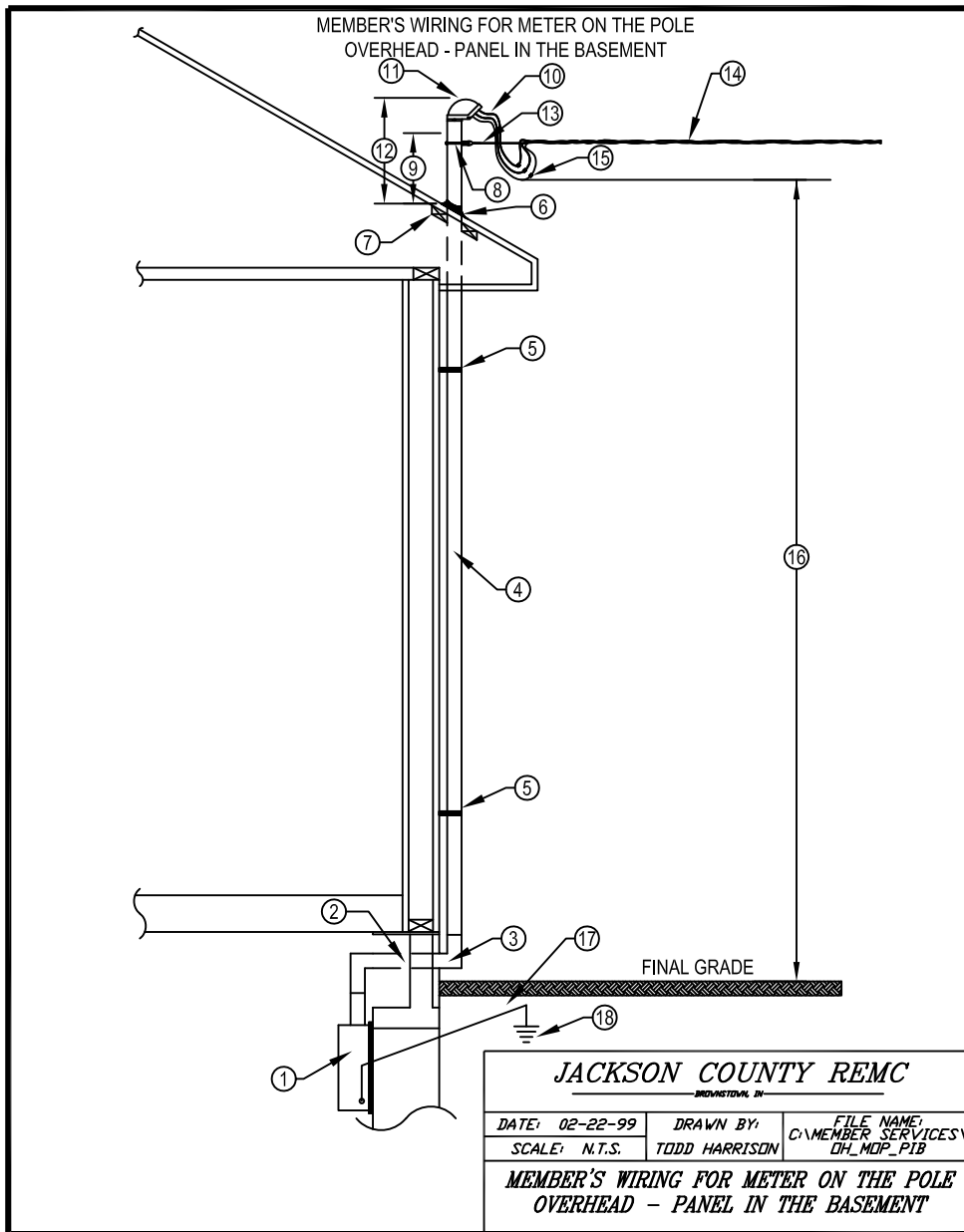

- 7.) Two inch by four inch wood blocking between the rafters should be installed in order to give stability to the riser.
- 8.) Install a two inch riser clevis around the two inch riser. The riser clevis is where the overhead triplex will fasten to the riser.
- 9.) The riser clevis has to be at least eighteen inches above the neoprene roof flashing boot at the service entrance locations.
- 10.) Install the service entrance conductors in the riser leaving approximately twenty-four inches hanging out of the riser. The neutral conductor needs to be properly identified with a six inch wide marking of white electrical tape. See chart 1D for service entrance conductor sizing.
- 11.) Install a two inch weatherhead on top of the rigid meter conduit. The service entrance conductors should hang out of the weatherhead approximately eighteen to twenty inches.
- 12.) The weatherhead should not be higher than three feet above the roof. This is from the lowest point where the riser exits the roof to the top of the weatherhead.
- 13.) Install a wedge clamp to connect the overhead triplex to the riser clevis.
- 14.) Furnish the proper size overhead triplex wire to the meter pole. Measure off the distance and add **ten** feet to the total length of the triplex. Overhead triplex sizes can be found on chart 1F. **Do not attempt to connect the triplex at the meter pole;** REMC will make the connection.

- 15.) Connect the service entrance conductors to the overhead triplex forming a drip loop on the wires. Connections can be made with cadmium connectors, split bolts, or compression fittings.
 - A.) Cadmium connectors can and should be used to connect aluminum conductors to copper conductors.
 - B.) Split bolt connectors can be used to connect copper conductors to copper conductors only.
 - C.) Compression fittings or "H" crimps can be used to connect either aluminum or copper conductors to each other.
 - D.) Once you have made the connections, each individual connection should be wrapped with electrical insulating pads followed by black electrical tape.
- 16.) The service conductors must meet the following clearances from final grade.
 - A.) 10 feet clearance at the service entrance; at the lowest point of the drip loop; at areas accessible to pedestrians; above sidewalks.
 - B.) 12 feet clearance over residential property and driveways.
 - C.) 18 feet clearance over public roads.

- 17.) Install a grounding electrode (ground rod) approximately eighteen inches away from the foundation of the building. The grounding electrode needs to be approximately six inches below final grade. Leave the top of the grounding electrode and the grounding clamp exposed until a Rural Electric employee has performed a safety check. Grounding electrode and clamp sizing can be found on chart 1B.

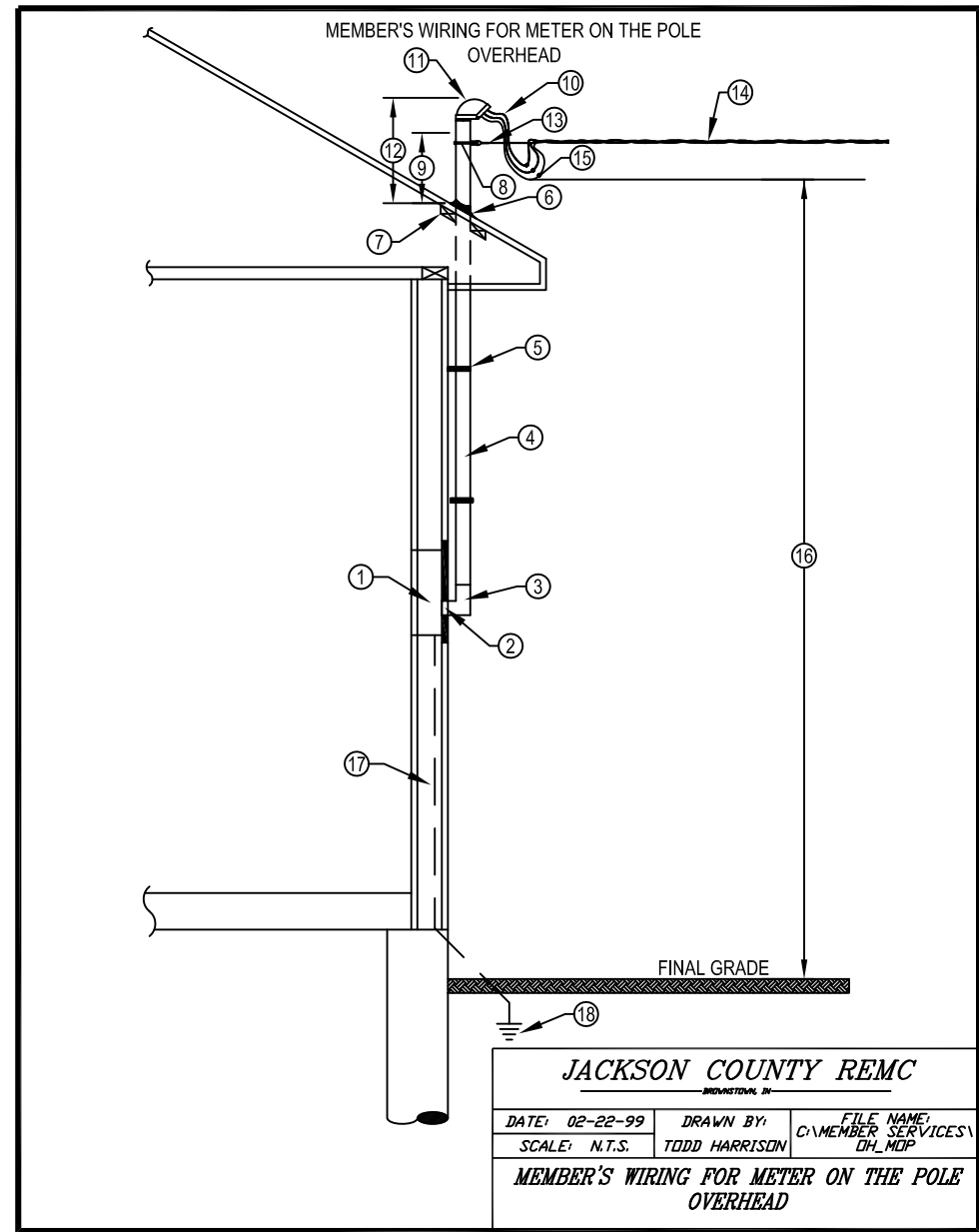

**MEMBER'S WIRING FOR METER
ON THE POLE OVERHEAD**

A Rural Electric staking engineer must approve meter locations.

- 1.) Securely fasten the electrical service entrance panel to the interior structure of the building. Normally the service panel is recessed in the wall between two 2 X 4's.
- 2.) Install a steel nipple or PVC adapter between the "LB" and the service entrance panel. A steel locknut and a grounding bushing should be installed on the threaded portion of the steel nipple that is located in the panel. See chart 1C for service entrance conduit sizing.
- 3.) Install an electrical 90 degree steel or PVC "LB". See chart 1E for "LB" sizing.
- 4.) Install a two inch rigid steel piece of conduit from the "LB" up through the roof and extending above the roof no more than 36".
- 5.) Securely fasten the two inch rigid steel conduit riser to the structure of the building with conduit standoff brackets or two hole straps.
- 6.) Install a two inch neoprene roof flashing boot over the newly installed rigid steel riser to prevent water from leaking around the riser.
- 7.) Two inch by four inch wood blocking between the rafters should be installed in order to give stability to the riser.
- 8.) Install a two inch riser clevis around the two inch riser. The riser clevis is where the overhead triplex will fasten to the riser.
- 9.) The riser clevis should be at least eighteen inches above the neoprene roof flashing boot at the service entrance locations.
- 10.) Install the service entrance conductors in the riser leaving approximately twenty-four inches hanging out of the top of the riser. The neutral conductor needs to be properly identified with a six inch wide marking of white electrical tape. See chart 1D for service entrance conductor sizing.
- 11.) Install a two inch weatherhead on top of the rigid meter conduit. The service entrance conductors should hang out of the weatherhead approximately eighteen to twenty inches.
- 12.) The weatherhead should not be higher than three feet above the roof. This is from the lowest point where the riser exits the roof to the top of the weatherhead.
- 13.) Install a wedge clamp connecting the overhead triplex to the riser clevis.
- 14.) Furnish the overhead triplex wire to the meter pole. Measure off the distance and add **ten** feet to the total length of the triplex. Overhead triplex sizes can be found on chart 1F. **Do not attempt to connect the triplex at the meter pole;** REMC will make the connection.

15.) Connect the service entrance conductors to the overhead triplex forming a drip loop in the wires. Connections can be made with cadmium connectors, split bolts, or compression fittings.

- A.) Cadmium connectors can and should be used to connect aluminum conductors to copper conductors.
- B.) Split bolt connectors can be used to connect copper conductors to copper conductors only.
- C.) Compression fitting or "H" crimps if available can be used to connect aluminum or copper conductors to each other.
- D.) Once you have made the connections, each individual connection should be wrapped with electrical insulating pads followed by black electrical tape.

16.) The service conductors must meet the following clearances from final grade:

- A.) 10 feet clearance at the service entrance; at the lowest point of the drip loop; at areas accessible to pedestrians; above sidewalks.
- B.) 12 feet clearance over residential property and driveways.
- C.) 18 feet clearance over public roads.

17.) Install a grounding conductor from the panel out to a grounding electrode. See chart 1A for grounding conductor sizing.

18.) Install a grounding electrode (ground rod) approximately eighteen inches away from the foundation of the building. The grounding electrode needs to be approximately six inches below final grade. Leave the top of the grounding electrode and the grounding clamp exposed until a Rural Electric employee has performed a safety check. Grounding electrode and clamp sizing can be found on chart 1B.

**MEMBER'S WIRING FOR METER ON THE POLE
OVERHEAD GABLE CONNECTION**

A Rural Electric staking engineer must approve meter base locations.

- 1.) Securely fasten the electrical service entrance panel to the interior structure of the building. The service panel is usually recessed in the wall between two 2 X 4's.
- 2.) Install a steel or PVC nipple between the "LB" and the service entrance panel. If a steel nipple is used, then a steel locknut and a grounding bushing should be installed on the threaded portion of the nipple that is located in the service entrance panel. See charts 1C and 1E for conduit and "LB" sizing.
- 3.) Install an electrical 90 degree steel or PVC "LB". See chart 1E for "LB" sizing.
- 4.) Install schedule 80 gray electrical PVC or rigid steel from the "LB" up to a point thirteen feet above final grade. See chart 1C for conduit sizes.
- 5.) Securely fasten the riser to the building with conduit standoff brackets or two hole straps.
- 6.) Install the service entrance conductors in the riser leaving approximately twenty-four inches hanging out of the top of the riser. The neutral conductor should be properly identified with a six inch wide marking of white electrical tape. See chart 1D for service entrance conductor sizing.

MEMBER'S WIRING FOR METER ON THE POLE
OVERHEAD - GABLE CONNECTION

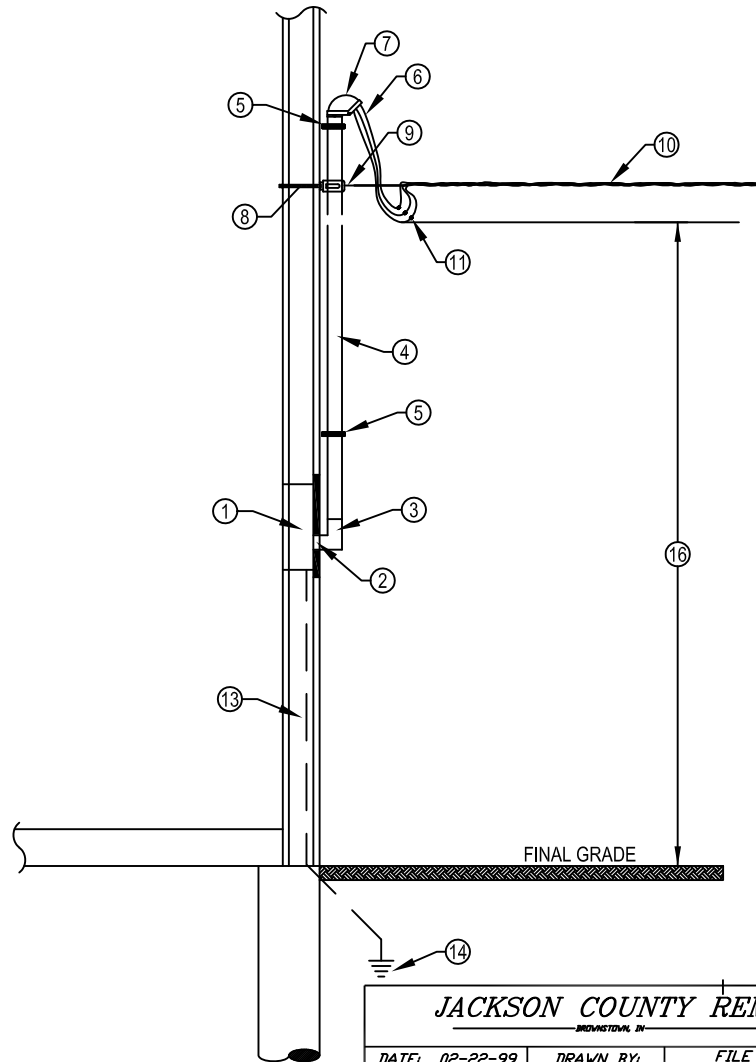

JACKSON COUNTY REMC <small>INDIANAPOLIS, IN</small>		
DATE: 02-22-99	DRAWN BY: TODD HARRISON	FILE NAME: C:\MEMBER SERVICES\DH_MDP_GABLE
SCALE: N.T.S.		
MEMBER'S WIRING FOR METER ON THE POLE OVERHEAD - GABLE CONNECTION		

- 7.) Install a weatherhead on top of the riser. The service entrance conductors should hang out of the weatherhead approximately eighteen to twenty inches.
- 8.) Install a 5/8" electrical eyebolt through the framing of the building. The eyebolt needs to be installed a minimum of twelve feet above final grade.
- 9.) Install a wedge clamp to connect the overhead triplex to the eye bolt.
- 10.) The member will need to supply the overhead triplex from the riser to the REMC meter pole location. Measure off the distance to the meter location and add five feet to the total length of the triplex. Overhead triplex sizes can be found on chart 1F.
- 11.) Connect the service entrance conductors to the overhead triplex forming a drip loop in the wires. Connections can be made with cadmium connectors, split bolts, or compression fittings.
 - A.) Cadmium connectors can and should be used to connect aluminum conductors to copper conductors.
 - B.) Split bolt connectors can be used to connect copper conductors to copper conductors only.
 - C.) Compression fittings of "H" crimps if available can be used to connect aluminum or copper conductors to each other.

- D.) Once you have made the connections, each individual connection should be wrapped with electric insulating pads followed by black electrical tape.
- 12.) The service conductors must meet the following clearances from final grade:
 - A.) 10 feet clearance at the service entrance; at the lowest point to the drip loop; at areas accessible to pedestrians, above sidewalks.
 - B.) 12 feet clearance over residential property and driveways.
 - C.) 18 feet clearance over public roads.
 - 13.) Install a grounding conductor from the panel out to a grounding electrode. See chart 1A for grounding conductor sizing.
 - 14.) Install a grounding electrode (ground rod) approximately eighteen inches away from the foundation of the building. The grounding electrode needs to be approximately six inches below final grade. Leave the grounding electrode and grounding clamp exposed until a Rural Electric employee has performed a safety check. Grounding electrode and clamp sizing can be found on chart 1B.

CHART 1A

GROUNDING CONDUCTOR SIZING	
ELECTRICAL SERVICE ENTRANCE SIZE IN AMPERES	GROUNDING ELECTRODE SIZING
100 AMP	#6 SOLID COPPER
200 AMP	#4 SOLID COPPER

CHART 1B

GROUNDING ELECTRODE SIZING		
ELECTRICAL SERVICE ENTRANCE SIZE IN AMPERES	GROUNDING ELECTRODE SIZING	GROUND ROD CLAMP
100 AMP	1/2" X 8' COPPER GROUND ROD	JAB58H
200 AMP	5/8" X 8' COPPER GROUND ROD	JAB58H

CHART 1C

CONDUIT SIZING		
SERVICE SIZE	RIGID STEEL	SCHEDULE 80 PVC
100 AMP	2"	2"
200 AMP	2"	2"

NOTE: ANYTIME CONDUIT IS EXTENDED ABOVE A ROOF LINE, THE CONDUIT NEEDS TO BE 2" RIGID STEEL.

JACKSON COUNTY REMC <small>INDIANAPOLIS, IN</small>		
DATE: 02-22-99	DRAWN BY: TODD HARRISON	FILE NAME: C:\MEMBER SERVICES\DH_CHART
SCALE: N.T.S.	MEMBER'S SIZING CHART	

CHART 1D

SERVICE ENTRANCE CONDUCTOR SIZING		
SERVICE SIZE	COPPER "THWN"	ALUMINUM USE / RHH / RHW
100 AMP	#2	#2
200 AMP	3/0	4/0

NOTE: WHENEVER ALUMINUM SERVICE ENTRANCE CONDUCTORS ARE USED, CORROSION INHIBITING GREASE WILL NEED TO BE APPLIED TO ALL EXPOSED ALUMINUM CONDUCTORS.

CHART 1E

"LB" SIZING	
SERVICE SIZE	"LB" SIZE
100 AMP	2" LB
200 AMP	2" LB

NOTE: ANYTIME CONDUIT IS EXTENDED ABOVE A ROOF LINE, THE CONDUIT AND FITTINGS (LB) NEED TO BE 2" RIGID STEEL

CHART 1F

OVERHEAD TRIPLEX WIRE SIZING	
SERVICE SIZE	OVERHEAD TRIPLEX SIZE
100 AMP	#2 TRIPLEX
200 AMP	1/0 TRIPLEX

JACKSON COUNTY REMC <small>INDIANAPOLIS, IN</small>		
DATE: 02-22-99	DRAWN BY: TODD HARRISON	FILE NAME: C:\MEMBER SERVICES\DH_CHART
SCALE: N.T.S.	MATERIAL SIZING CHARTS FOR SERVICE ENTRANCES	



Jackson County REMC

PO Box K, Brownstown IN 47220
812-358-4458 / 800-288-4458 Toll free / 812-358-5719 FAX
e-mail: info@jacksonremc.com website: www.jacksonremc.com

Your Touchstone Energy Cooperative 
The power of human connections

Avoid Power Line Easement Encroachment!

Keep all structures at least 20 feet away from power lines and poles! If you have questions about power line easements, please call us at once. We'll be happy to meet with you to discuss your plans.

When you're planning to dig,
do your part. Call



two full working days
before you start!

Contact the Indiana Utility Plant Protection Service (also known as Holey Moley) to have any possible underground utilities located before you begin to dig.
In Indiana, it's the law!

**Danger!
High Voltage!**

Electric equipment may cause shock, burn, or death. If you find equipment open or unlocked or power lines on the ground,
CALL IMMEDIATELY!

This institution is an equal opportunity provider and employer.